

Serie

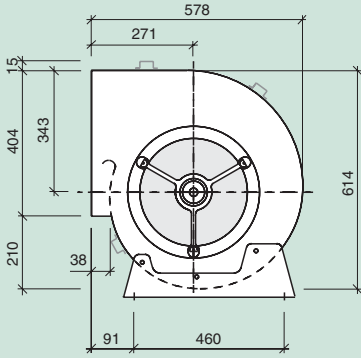

L

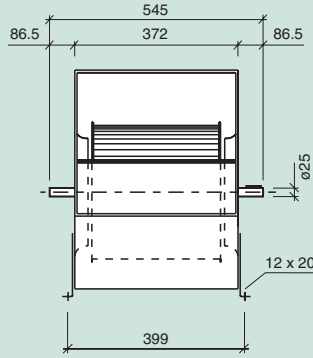

T2L

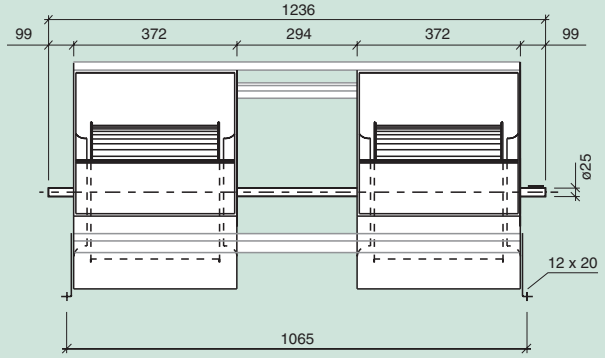

Serie

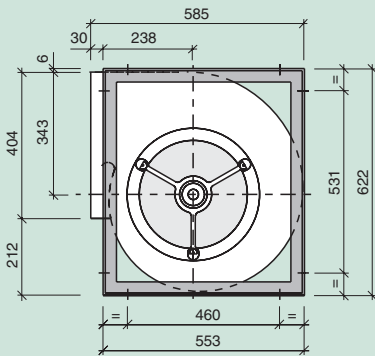

SR

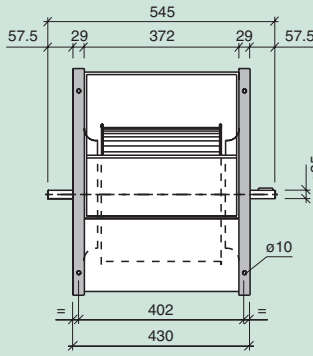

T2SR

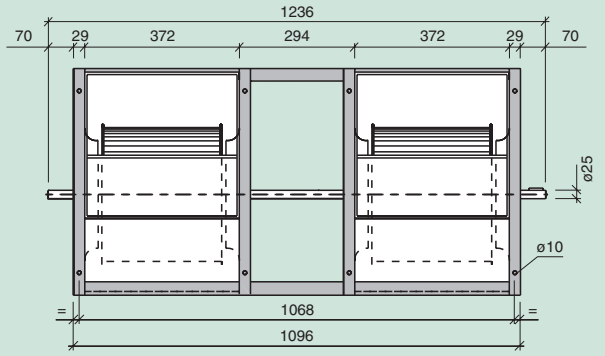

Serie

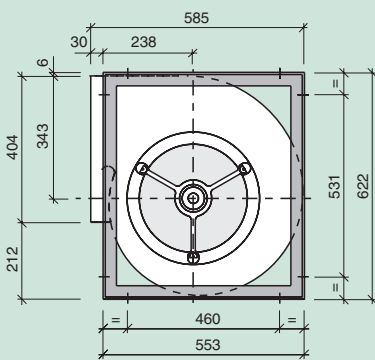

R

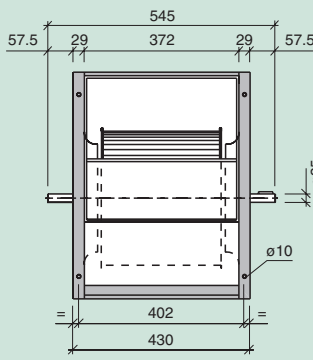

Serie

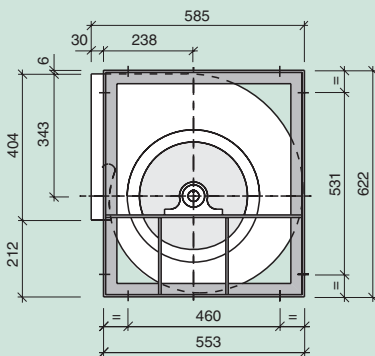

T2R

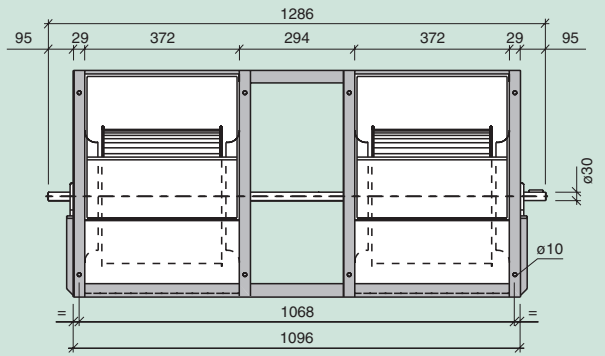

Serie - Series - Serie		L	SR	R	T2L	T2SR	T2R	T3R	
Límite de empleo. Operational limit. Limite d'emploi.	n max. motor max.	rpm kW	1200 3	1300 4	1400 5	1100 4	1200 5	1300 6	1100 8
Velocidad tangencial. Tip speed. Vitesse tangentielle.	u	m/s	n (min ⁻¹) x 0.0203						
Momento de inercia. Moment of inertia. Moment d'inertie.	PD ² /4	Kg m ²	0.23	0.23	0.23	0.46	0.46	0.46	0.69
Peso del ventilador. Fan weight. Poids du ventilateur.		Kg	20.5	23.5	24.5	44.5	45	61	95
Coefficientes de corrección. Correction factors. Coefficients de correction.	V P _A n	m ³ /h kW min ⁻¹	x 1 x 1 x 1	x 1 x 1 x 1	x 1 x 1 x 1	x 2 x 2.15 x 1.05	x 2 x 2.15 x 1.05	x 2 x 2.15 x 1.05	x 3 x 3.25 x 1.08

